

NOTES:

REVISIONS			
REV.	DESCRIPTION	DATE	APPROVED
A	FULL RELEASED	2023/12/1	CT

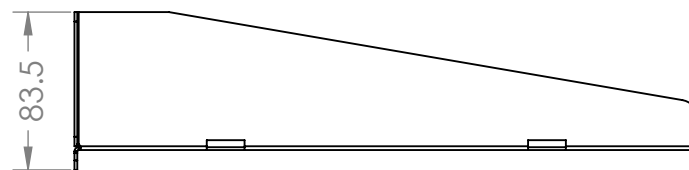
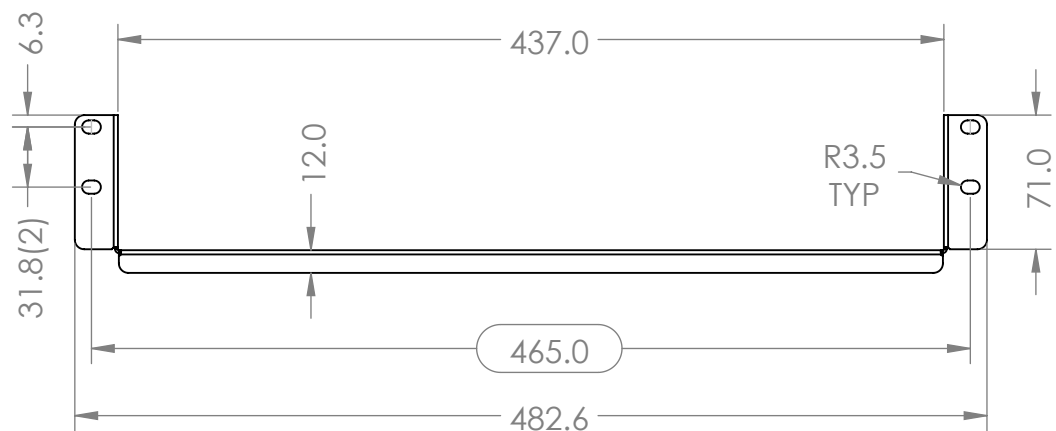
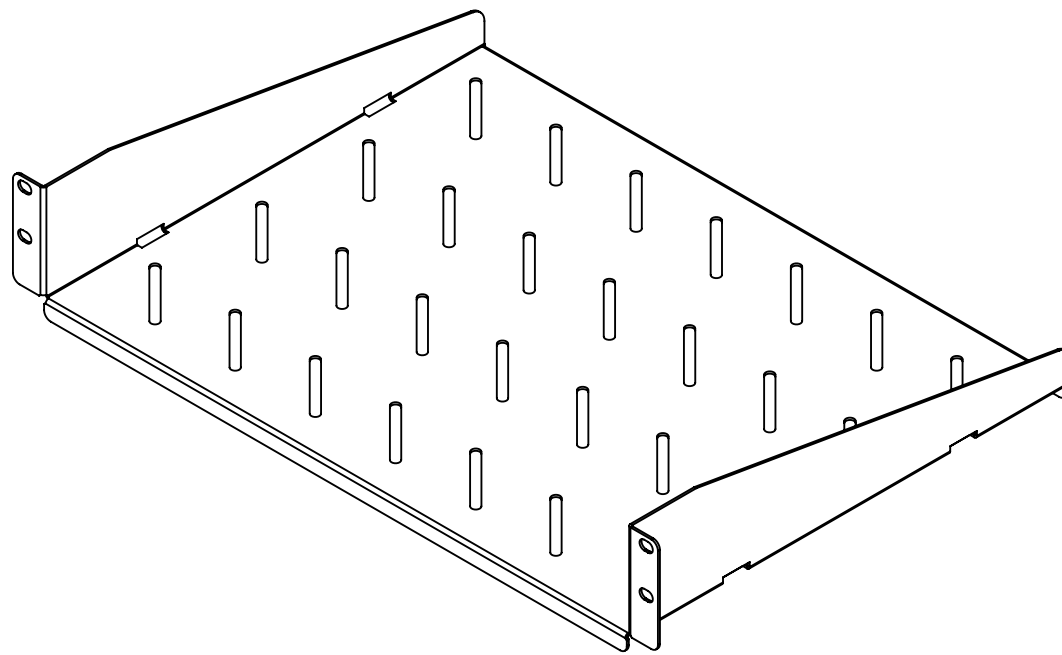
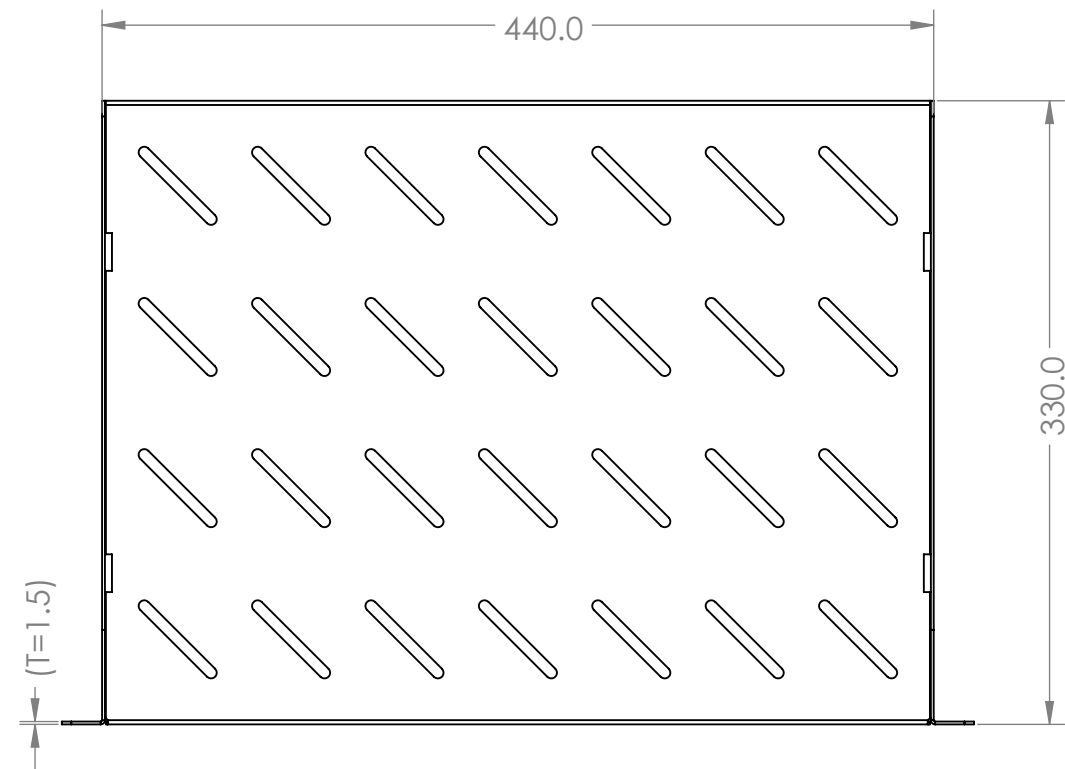

ACCESSORY BAG			
ITEM	PN.	DES.	QTY.
1	212-E600-00	NUT, INTEGRATED(SEMS),CAGE NUT, M6,BLACK ZINC PLATE	4
2	224-E600-00	WASHER, CUP WASHER, PLASTIC, BLACK, DIA X, THICKNESS X, HEIGHT X	4
3	201-E616-00	SCREW, ROUNDED HEAD, M6X16 PHILLIPS, BLACK ZINC, GRADE 8.8	4

PROPRIETARY AND CONFIDENTIAL

THIS DRAWING AND ITS SPECIFICATIONS ARE THE PROPERTY OF INOVA AND SHALL NOT BE COPIED, REPRODUCED, OR USED IN WHOLE OR IN PART, AS THE BASIS FOR THE MANUFACTURE OR SALE OF ITEMS WITHOUT THE WRITTEN PERMISSION FROM INOVA. THIS DRAWING IS BASED UPON THE LATEST AVAILABLE INFORMATION AND IS SUBJECT TO CHANGE WITHOUT NOTICE.

UNLESS OTHERWISE SPECIFIED

- X = ± 1
- X.X = ± 0.5
- X.XX = ± 0.30
- X.XXX = ± 0.130
- ANGULAR
- X = 1°
- .X = 0.5°
- .XX = 0.25°



UNITS: mm [in]



INTERPRET TO ASME Y14.100

DESCRIPTION:
RACK SHELF 2U, 332MM DEPTH,
RAL9005, 1PCS

MATERIAL:
1.5MM SPCC

FINISH:
RAL 9005 TEXTURE

DEBURR AND BREAK SHARP
EDGES/CONTOURS AT 0.2mm MAX

CLASS: N/A

DRAWING NO:

INV08-00001

REV NO:

A
SIZE: B

NAME	DATE	COMMENTS:
DRAWN BY: AMY ZHU	2023/12/1	
APP. BY: SAM DING	2023/12/1	

SCALE: 1:4 WEIGHT: SHEET: 1 OF 1