

NOTES:

REVISIONS			
REV.	DESCRIPTION	DATE	APPROVED
A	FULL RELEASED	2023/11/30	CT

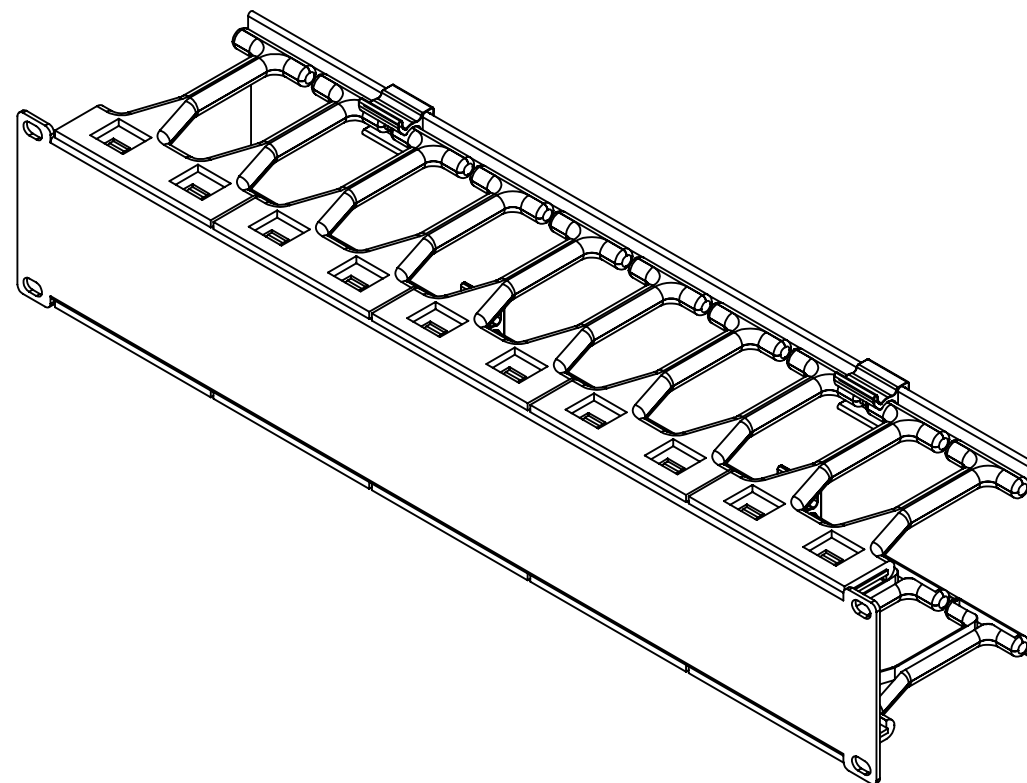
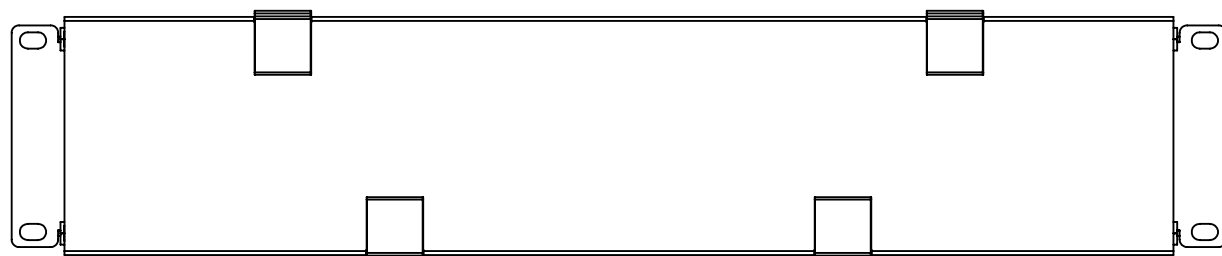

ACCESSORY BAG			
ITEM	PN.	DES.	QTY.
1	212-E600-00	NUT, INTEGRATED(SEMS),CAGE NUT, M6,BLACK ZINC PLATE	4
2	224-E600-00	WASHER, CUP WASHER, PLASTIC, BLACK, DIA X, THICKNESS X, HEIGHT X	4
3	201-E616-00	SCREW, ROUNDED HEAD, M6X16 PHILLIPS, BLACK ZINC, GRADE 8.8	4

PROPRIETARY AND CONFIDENTIAL
 THIS DRAWING AND ITS SPECIFICATIONS ARE THE PROPERTY OF INOVA AND SHALL NOT BE COPIED, REPRODUCED, OR USED IN WHOLE OR IN PART, AS THE BASIS FOR THE MANUFACTURE OR SALE OF ITEMS WITHOUT THE WRITTEN PERMISSION FROM INOVA. THIS DRAWING IS BASED UPON THE LATEST AVAILABLE INFORMATION AND IS SUBJECT TO CHANGE WITHOUT NOTICE.

UNLESS OTHERWISE SPECIFIED

X = ± 1
 X.X = ± 0.5
 X.XX = ± 0.30
 X.XXX = ± 0.130
 ANGULAR
 X = 1°
 .X = 0.5°
 .XX = 0.25°

UNITS: mm [in]



DESCRIPTION:
CABINET ACCESSORY, 2U FINGER CABLE MANAGER WITH COVER, BLACK

MATERIAL: 2MM CRS, 1.5MM OR 3mm ALUMINUM AND PLASTIC FINISH: RAL9005 TEXTURE

DEBURR AND BREAK SHARP EDGES/CONTOURS AT 0.2mm MAX CLASS: N/A

DRAWING NO: **INV08-00010B**

REV NO: **A**
 SIZE: **B**

NAME	DATE	COMMENTS:
DRAWN BY: AMY ZHU	2023/11/30	
APP. BY: SAM DING	2023/11/30	

SCALE: 1:3 WEIGHT: SHEET: 1 OF 2

NOTES:

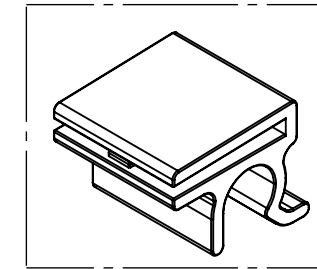
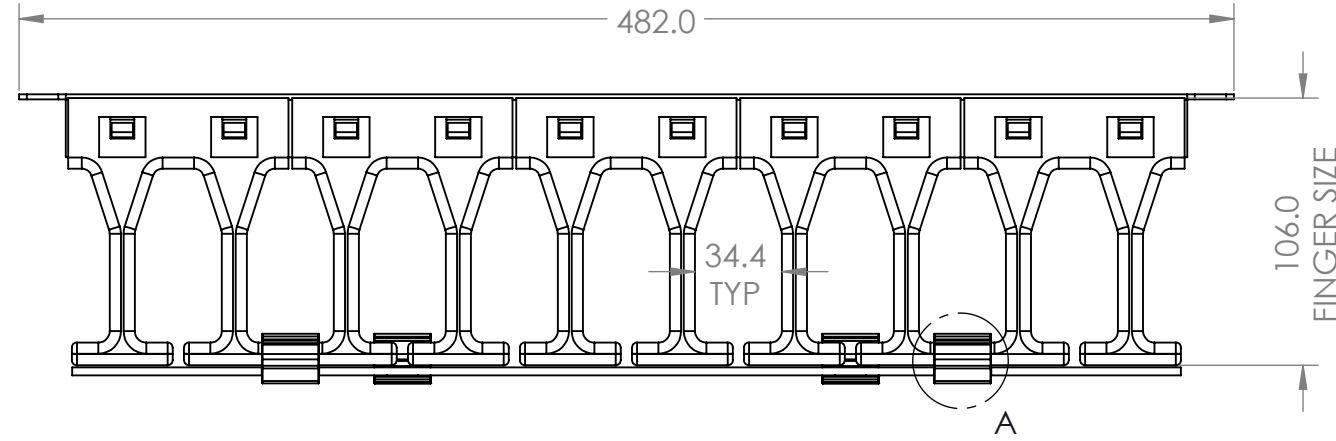

DETAIL A

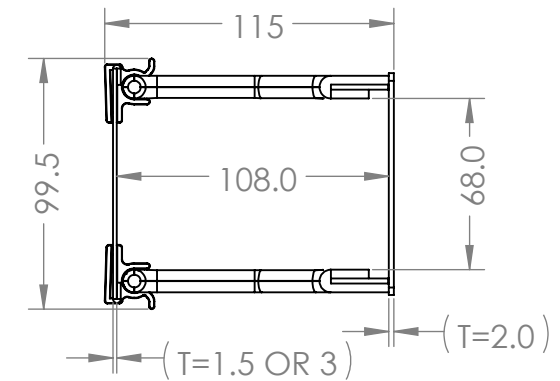
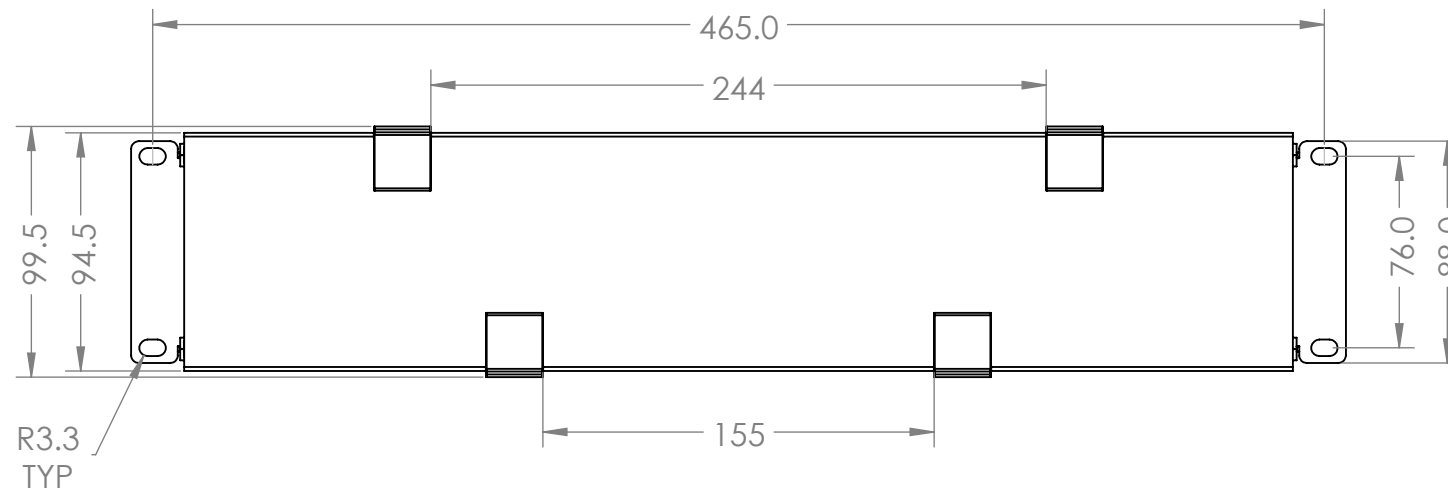

PROPRIETARY AND CONFIDENTIAL

THIS DRAWING AND ITS SPECIFICATIONS ARE THE PROPERTY OF INOVA AND SHALL NOT BE COPIED, REPRODUCED, OR USED IN WHOLE OR IN PART, AS THE BASIS FOR THE MANUFACTURE OR SALE OF ITEMS WITHOUT THE WRITTEN PERMISSION FROM INOVA. THIS DRAWING IS BASED UPON THE LATEST AVAILABLE INFORMATION AND IS SUBJECT TO CHANGE WITHOUT NOTICE.

UNLESS OTHERWISE SPECIFIED

X = ± 1
 X.X = ± 0.5
 X.XX = ± 0.30
 X.XXX = ± 0.130
 ANGULAR
 X = 1°
 .X = 0.5°
 .XX = 0.25°



UNITS: mm [in]



INTERPRET TO ASME Y14.100

DESCRIPTION:
**CABINET ACCESSORY, 2U
 FINGER CABLE MANAGER
 WITH COVER, BLACK**

MATERIAL: 2MM CRS, 1.5MM OR 3mm ALUMINUM AND PLASTIC FINISH: RAL9005 TEXTURE

DEBURR AND BREAK SHARP EDGES/CONTOURS AT 0.2mm MAX CLASS: N/A

DRAWING NO:

INV08-00010B

REV NO:

A

SIZE:
B

NAME	DATE	COMMENTS:
DRAWN BY: AMY ZHU	2023/11/30	
APP. BY: SAM DING	2023/11/30	

SCALE: 1:3 WEIGHT: SHEET: 2 OF 2