

8 7 6 5 4 3 2 1

NOTES:

REVISIONS			
REV.	DESCRIPTION	DATE	APPROVED
A	FULL RELEASED	2023/11/30	CT

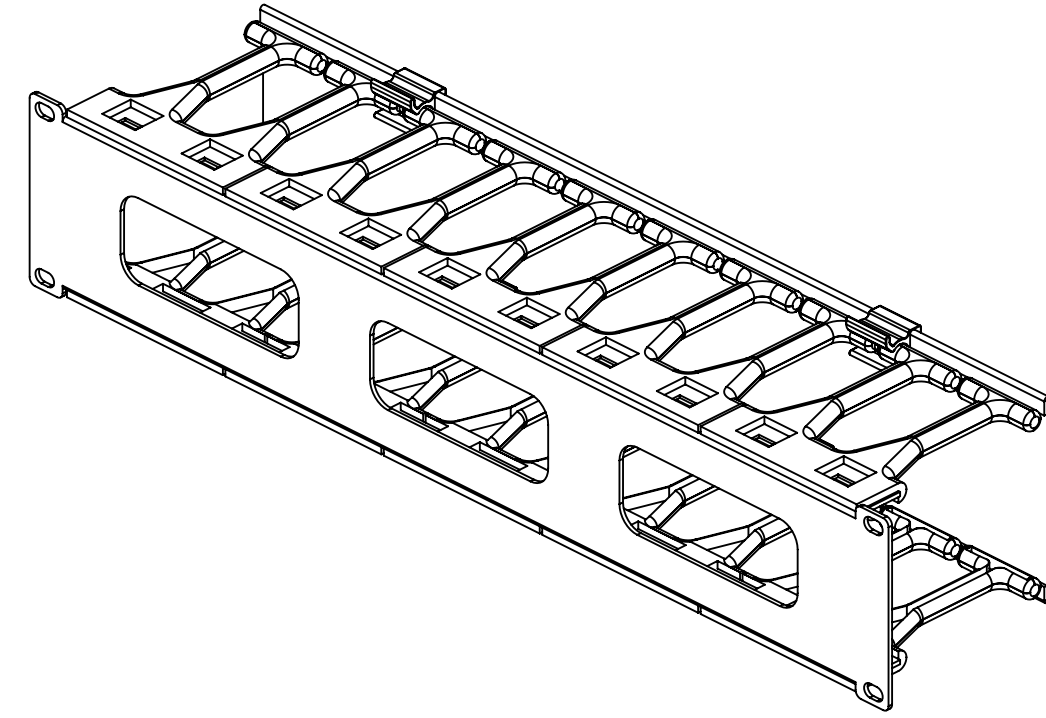
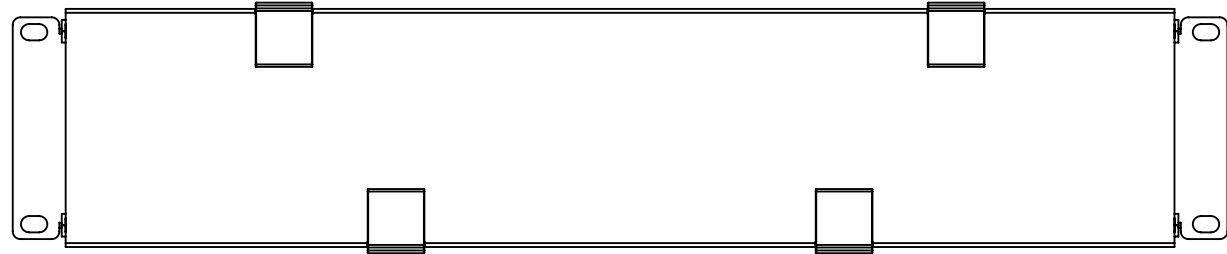

ACCESSORY BAG			
ITEM	PN.	DES.	QTY.
1	212-E600-00	NUT, INTEGRATED(SEMS),CAGE NUT, M6,BLACK ZINC PLATE	4
2	224-E600-00	WASHER, CUP WASHER, PLASTIC, BLACK, DIA X, THICKNESS X, HEIGHT X	4
3	201-E616-00	SCREW, ROUNDED HEAD, M6X16 PHILLIPS, BLACK ZINC, GRADE 8.8	4

**PROPRIETARY AND CONFIDENTIAL**  
 THIS DRAWING AND ITS SPECIFICATIONS ARE THE PROPERTY OF INOVA AND SHALL NOT BE COPIED, REPRODUCED, OR USED IN WHOLE OR IN PART, AS THE BASIS FOR THE MANUFACTURE OR SALE OF ITEMS WITHOUT THE WRITTEN PERMISSION FROM INOVA. THIS DRAWING IS BASED UPON THE LATEST AVAILABLE INFORMATION AND IS SUBJECT TO CHANGE WITHOUT NOTICE.

UNLESS OTHERWISE SPECIFIED  
 X = ± 1  
 X.X = ± 0.5  
 X.XX = ± 0.30  
 X.XXX = ± 0.130  
 ANGULAR  
 X = 1°  
 .X = 0.5°  
 .XX = 0.25°  
 UNITS: mm [in]



DESCRIPTION:  
**CABINET ACCESSORY, 2U FINGER CABLE MANAGER WITH COVER, WITH CUTOUT, WHITE**  
 MATERIAL:  
 2.0MM SPCC 1.5MM OR 3MM AL AND PLASTIC  
 FINISH:  
 RAL 9003 TEXTURE  
 CLASS: N/A  
 DEBURR AND BREAK SHARP EDGES/CONTOURS AT 0.2mm MAX

DRAWING NO:  
**INV08-00013W**  
 REV NO:  
**A**  
 SIZE:  
**B**  
 COMMENTS:  
 DRAWN BY: AMY ZHU 2023/11/30  
 APP. BY: SAM DING 2023/11/30  
 SCALE: 1:3  
 WEIGHT:  
 SHEET: 1 OF 2

8 7 6 5 4 3 2 1

NOTES:

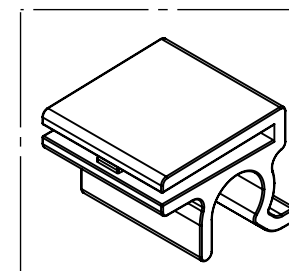
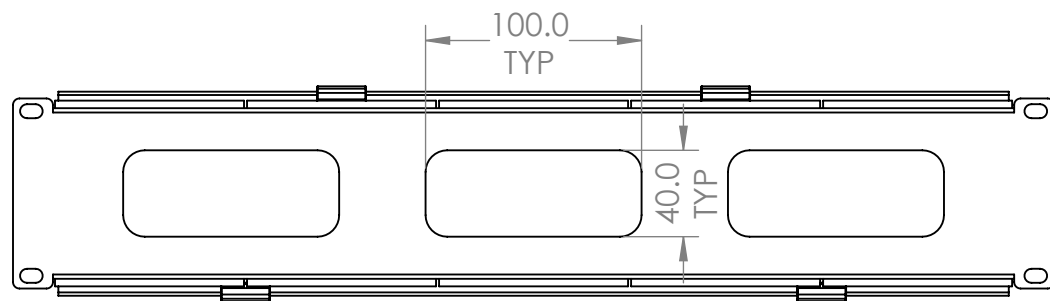

DETAIL A

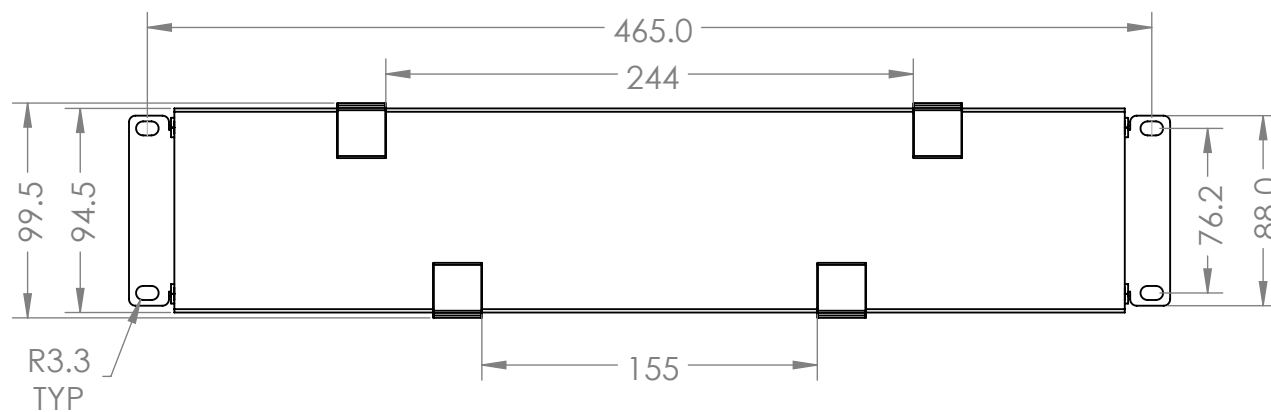
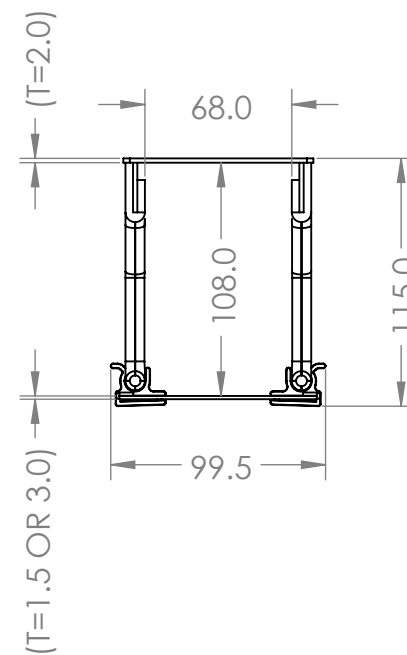
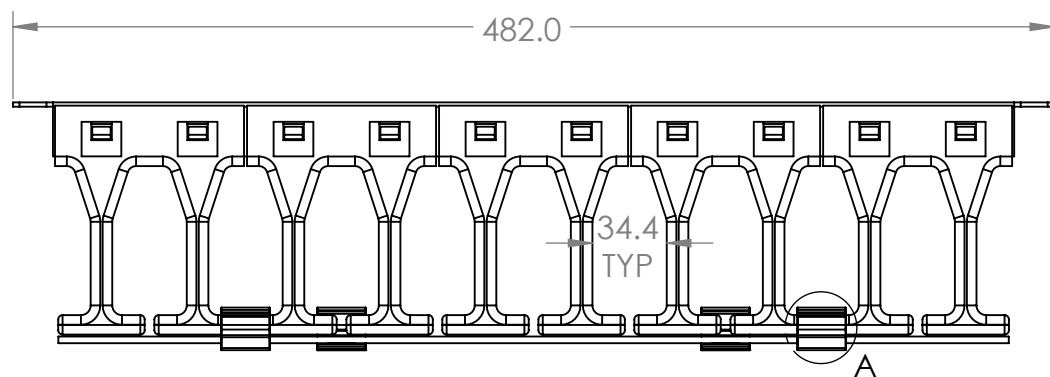

**PROPRIETARY AND CONFIDENTIAL**

THIS DRAWING AND ITS SPECIFICATIONS ARE THE PROPERTY OF INOVA AND SHALL NOT BE COPIED, REPRODUCED, OR USED IN WHOLE OR IN PART, AS THE BASIS FOR THE MANUFACTURE OR SALE OF ITEMS WITHOUT THE WRITTEN PERMISSION FROM INOVA. THIS DRAWING IS BASED UPON THE LATEST AVAILABLE INFORMATION AND IS SUBJECT TO CHANGE WITHOUT NOTICE.

UNLESS OTHERWISE SPECIFIED

X = ± 1  
 X.X = ± 0.5  
 X.XX = ± 0.30  
 X.XXX = ± 0.130  
 ANGULAR  
 X = 1°  
 .X = 0.5°  
 .XX = 0.25°



INTERPRET TO ASME Y14.100

DESCRIPTION:  
 CABINET ACCESSORY, 2U FINGER  
 CABLE MANAGER WITH COVER,  
 WITH CUTOUT, WHITE

MATERIAL:  
 2.0MM SPCC 1.5MM OR  
 3MM AL AND PLASTIC

FINISH:  
 RAL 9003 TEXTURE

DEBURR AND BREAK SHARP  
 EDGES/CONTOURS AT 0.2mm MAX

CLASS: N/A

DRAWING NO:

INV08-00013W

REV NO:

A  
 B

NAME		DATE		COMMENTS:
DRAWN BY	AMY ZHU	2023/11/30		
APP. BY	SAM DING	2023/11/30		

SCALE: 1:5

WEIGHT:

SHEET: 2 OF 2