

NOTES:

1. Item 3 pressed on past neck in Item 1.
2. Item 2 and Item 3 free to rotate about Item 1.
3. Minimum static weight rating of assembled unit is 650 lbs (295kg).
Load to be applied axially with at least three threads of engagement.
4. Use appropriate lubricant between Item 3 and Item 2 and between 3 and 1.
5. Assembly must withstand torque of 11 N-M (100 In-lbs).
6. Item to be ROHS compliant. Including any hardware.

REVISIONS			
REV.	DESCRIPTION	DATE	APPROVED
A	FULL RELEASED	2023/11/30	CT

D

D

C

C

B

B

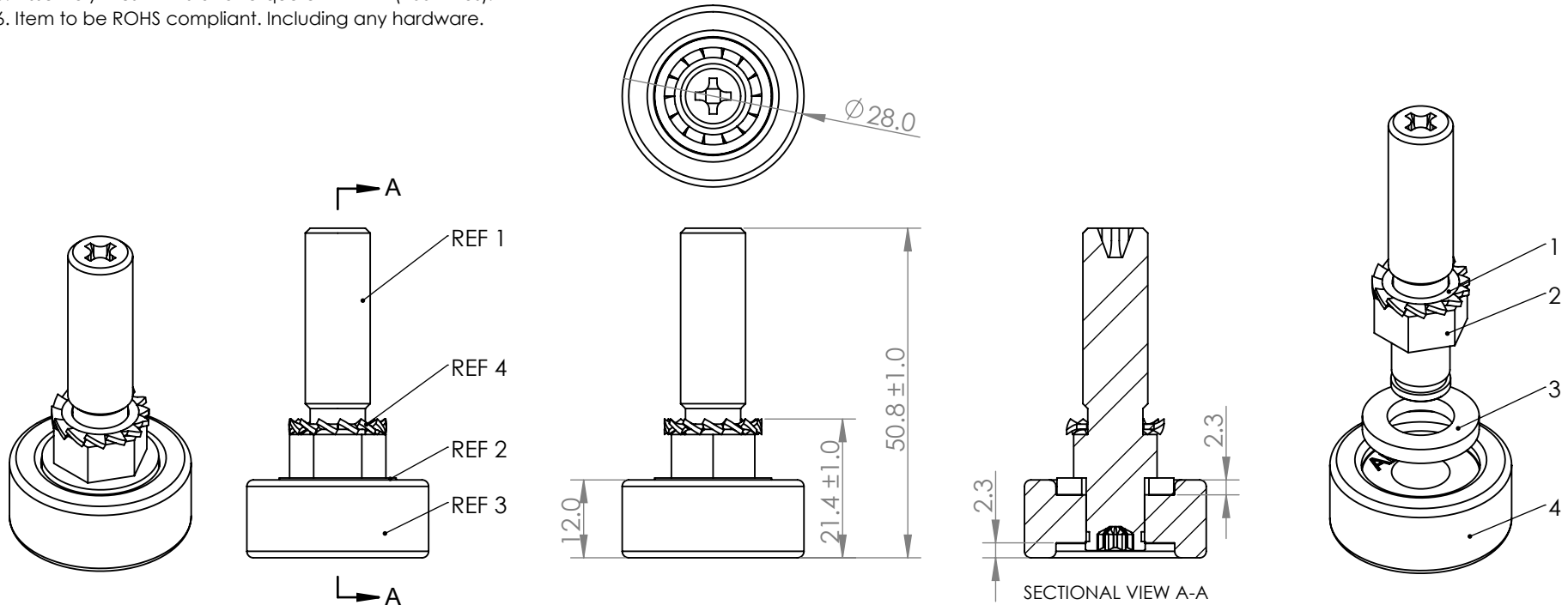

ITEM	PART	QTY.
1	WASHER EXT SERRATED LOCK ZP	1
2	STEM	1
3	WASHER	1
4	FOOT	1

A

A

PROPRIETARY AND CONFIDENTIAL
THIS DRAWING AND ITS SPECIFICATIONS ARE THE PROPERTY OF INOVA AND SHALL NOT BE COPIED, REPRODUCED, OR USED IN WHOLE OR IN PART, AS THE BASIS FOR THE MANUFACTURE OR SALE OF ITEMS WITHOUT THE WRITTEN PERMISSION FROM INOVA. THIS DRAWING IS BASED UPON THE LATEST AVAILABLE INFORMATION AND IS SUBJECT TO CHANGE WITHOUT NOTICE.

UNLESS OTHERWISE SPECIFIED	
X = ± 1	
X.X = ± 0.5	
X.XX = ± 0.30	
X.XXX = ± 0.130	
ANGULAR	
X = 1°	
.X = 0.5°	
.XX = 0.25°	
UNITS: mm [in]	



INTERPRET TO ASME Y14.100

DESCRIPTION:
CABINET ACCESSORY, LEVELING FEET, USE WITH 2" CASTORS, 4 PCS PER SET

MATERIAL: N/A FINISH: N/A

DEBURR AND BREAK SHARP EDGES/CONTOURS AT 0.2mm MAX CLASS: N/A

DRAWING NO: INV08-00016		REV NO: A
NAME: AMY ZHU		DATE: 2023/11/30
APP. BY: SAM DING		DATE: 2023/11/30
SCALE: 1:1	WEIGHT:	SHEET: 1 OF 1

5

4

3

2

1