

NOTES:  
 THE SKU INCLUDING:  
 2 PCS, PLATES FOR 2"CASTOR;  
 4 PCS, BOLTS 1/2X3 3/4IN;  
 4 PCS, BAYING BRACKETS;  
 8 PCS, PHILIPS PAN, SINK M5X12, BLACK ZINC;  
 4 PCS, WASHERS AND NUT 1/2 IN;  
 1 BOTTLE, EPOXT ADHESIVE.

REVISIONS			
REV.	DESCRIPTION	DATE	APPROVED
A	FULL RELEASED	2023/12/1	CT

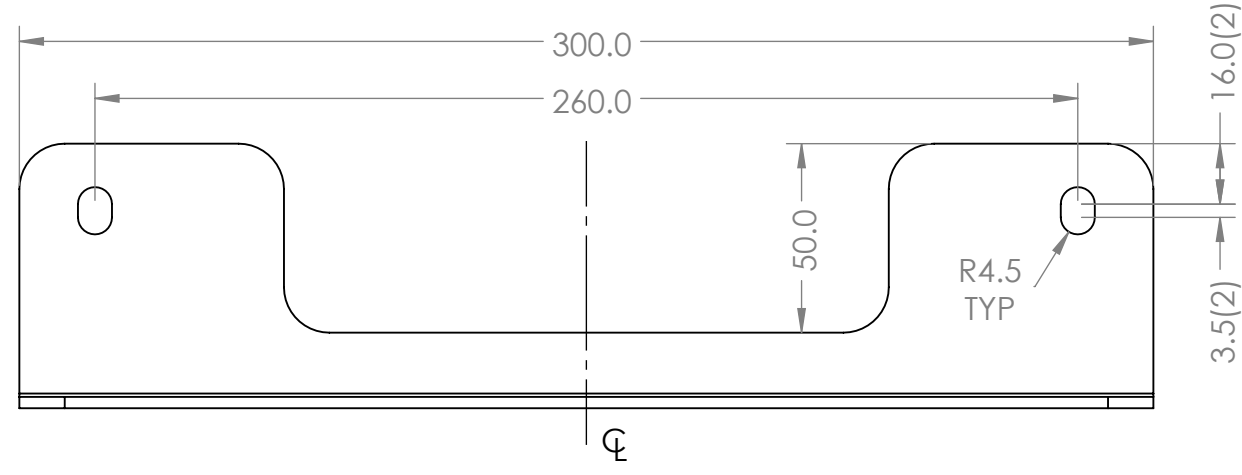
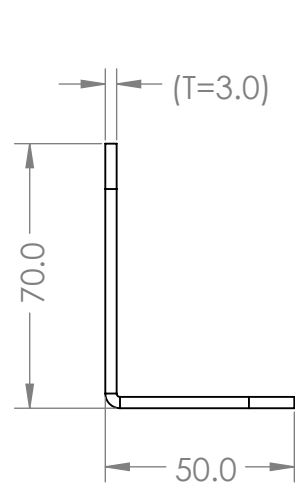
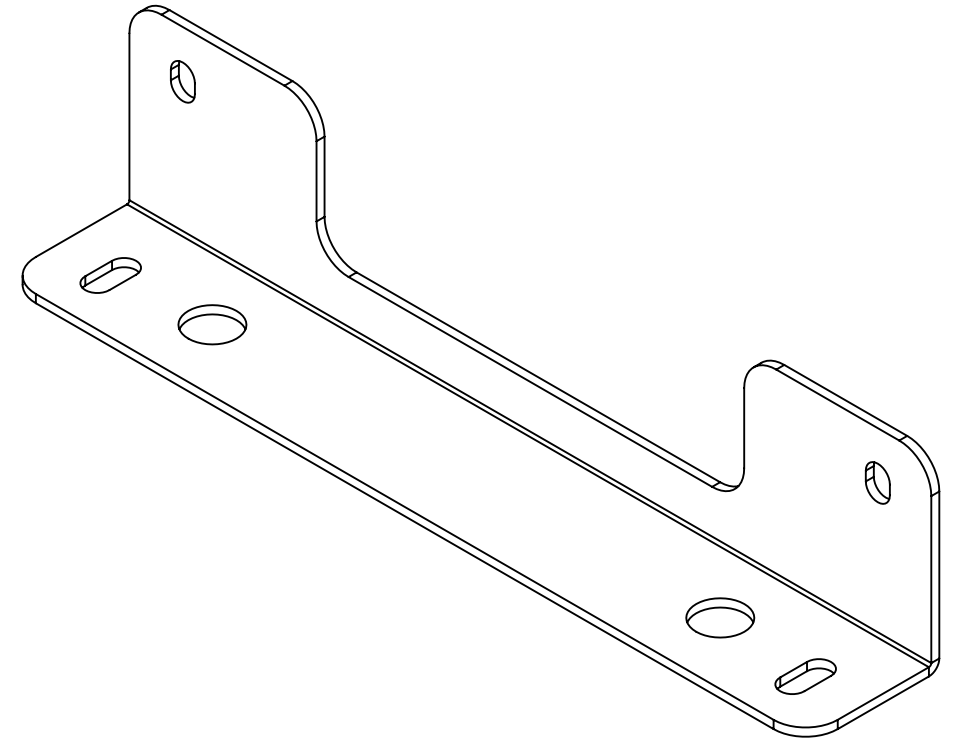
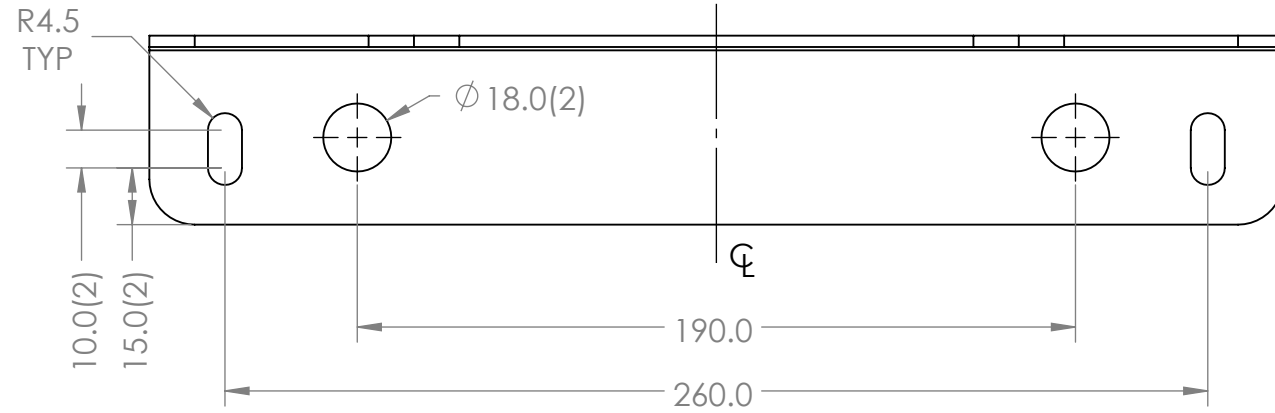

<b>PROPRIETARY AND CONFIDENTIAL</b> THIS DRAWING AND ITS SPECIFICATIONS ARE THE PROPERTY OF INOVA AND SHALL NOT BE COPIED, REPRODUCED, OR USED IN WHOLE OR IN PART, AS THE BASIS FOR THE MANUFACTURE OR SALE OF ITEMS WITHOUT THE WRITTEN PERMISSION FROM INOVA. THIS DRAWING IS BASED UPON THE LATEST AVAILABLE INFORMATION AND IS SUBJECT TO CHANGE WITHOUT NOTICE.	UNLESS OTHERWISE SPECIFIED X = ± 1 X.X = ± 0.5 X.XX = ± 0.30 X.XXX = ± 0.130 ANGULAR X = 1° .X = 0.5° .XX = 0.25°		DESCRIPTION: <b>CABINET ACCESSORY, ANCHOR BRACKET, 2 PCS PER SET WITH HARDWARES, BLACK</b>	DRAWING NO: <b>INV08-00017W</b>	REV NO: <b>A</b>	
	MATERIAL: 3.0MM SPCC		FINISH: RAL 9005 TEXTURE	NAME AMY ZHU	DATE 2023/12/1	COMMENTS:
	DEBURR AND BREAK SHARP EDGES/CONTOURS AT 0.2mm MAX		CLASS: N/A	APP. BY SAM DING	DATE 2023/12/1	
	INTERPRET TO ASME Y14.100		SCALE: 1:2	WEIGHT:	SHEET: 1 OF 1	