

NOTES:

REVISIONS			
REV.	DESCRIPTION	DATE	APPROVED
A	FULL RELEASED	2023/11/1	CT

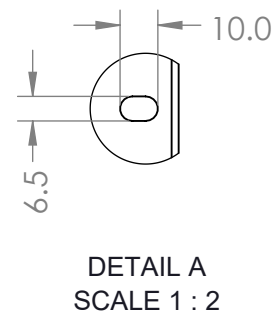
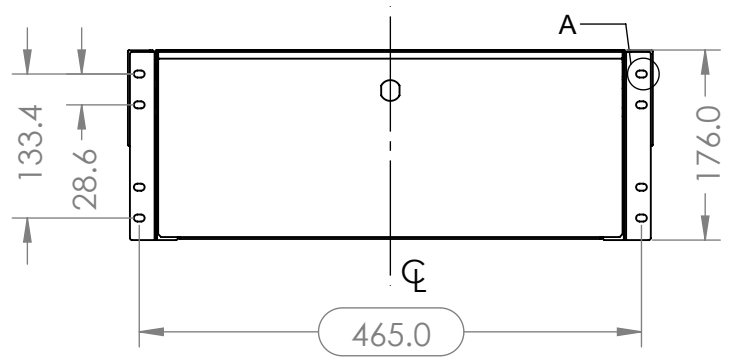
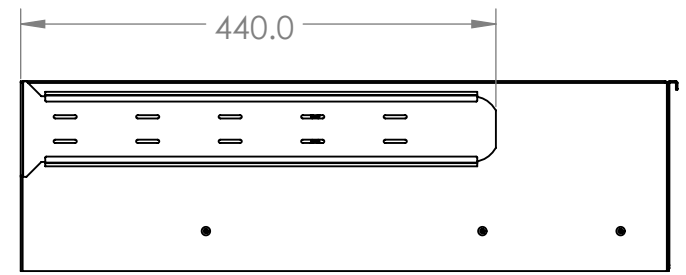
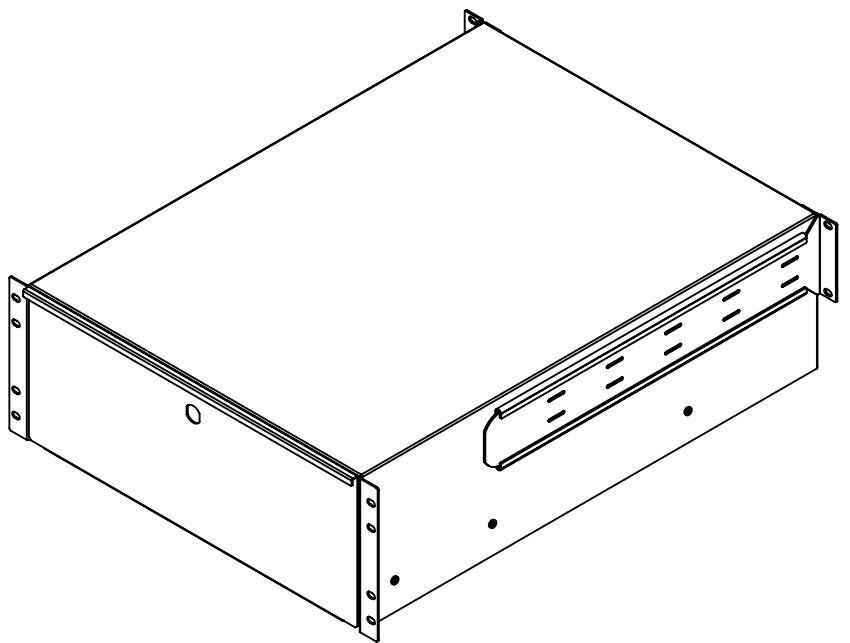
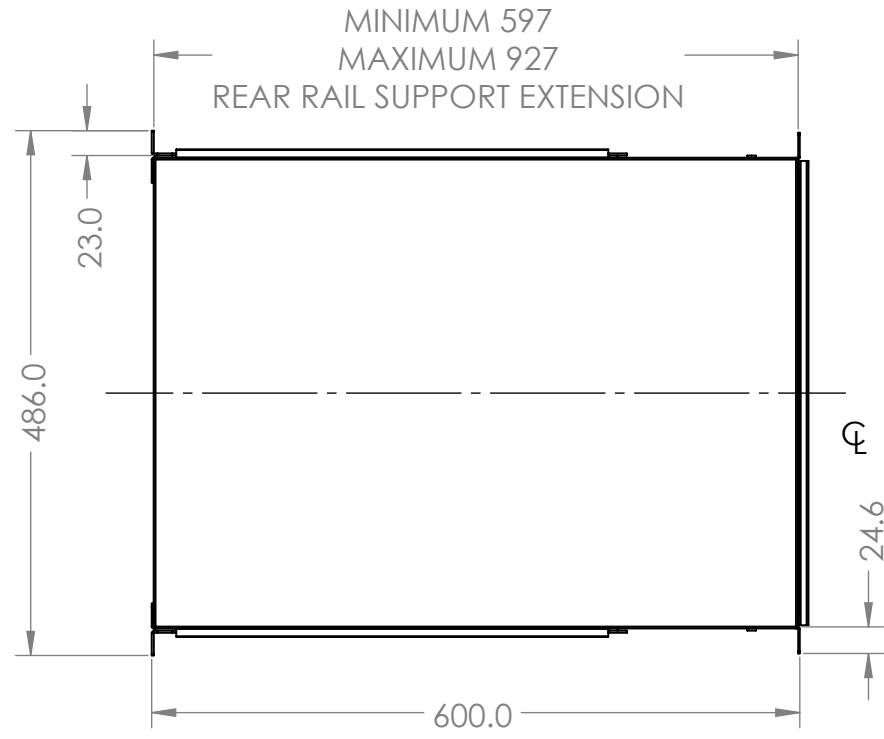

ACCESSORY BAG			
ITEM	PN.	DES.	QTY.
1	212-E600-00	NUT, INTEGRATED(SEMS),CAGE NUT, M6,BLACK ZINC PLATE	12
2	224-E600-00	WASHER, CUP WASHER, PLASTIC, BLACK, DIA X, THICKNESS X, HEIGHT X	12
3	201-E616-00	SCREW, ROUNDED HEAD, M6X16 PHILLIPS, BLACK ZINC, GRADE 8.8	12

**PROPRIETARY AND CONFIDENTIAL**  
 THIS DRAWING AND ITS SPECIFICATIONS ARE THE PROPERTY OF INOVA AND SHALL NOT BE COPIED, REPRODUCED, OR USED IN WHOLE OR IN PART, AS THE BASIS FOR THE MANUFACTURE OR SALE OF ITEMS WITHOUT THE WRITTEN PERMISSION FROM INOVA. THIS DRAWING IS BASED UPON THE LATEST AVAILABLE INFORMATION AND IS SUBJECT TO CHANGE WITHOUT NOTICE.

UNLESS OTHERWISE SPECIFIED  
 X = ± 1  
 X.X = ± 0.5  
 X.XX = ± 0.30  
 X.XXX = ± 0.130  
 ANGULAR  
 X = 1°  
 .X = 0.5°  
 .XX = 0.25°  
 UNITS: mm [in]



DESCRIPTION:  
**CABINET ACCESSORY, DRAWER, 4U,  
 19" WIDTH, 23.6" DEPTH, BLACK**

MATERIAL: SPCC FINISH: RAL 9005 TEXTURE

DEBURR AND BREAK SHARP EDGES/CONTOURS AT 0.2mm MAX CLASS: N/A

DRAWING NO: <b>INV08-DW04U</b>		REV NO: <b>A</b>
DRAWN BY: AMY ZHU DATE: 2023/11/1		SIZE: B
APP. BY: SAM DING DATE: 2023/11/1	COMMENTS:	
SCALE: 1:5	WEIGHT:	SHEET: 1 OF 1