

8 7 6 5 4 3 2 1

NOTES:

REVISIONS			
REV.	DESCRIPTION	DATE	APPROVED
A	FULL RELEASED	2023/12/1	CT

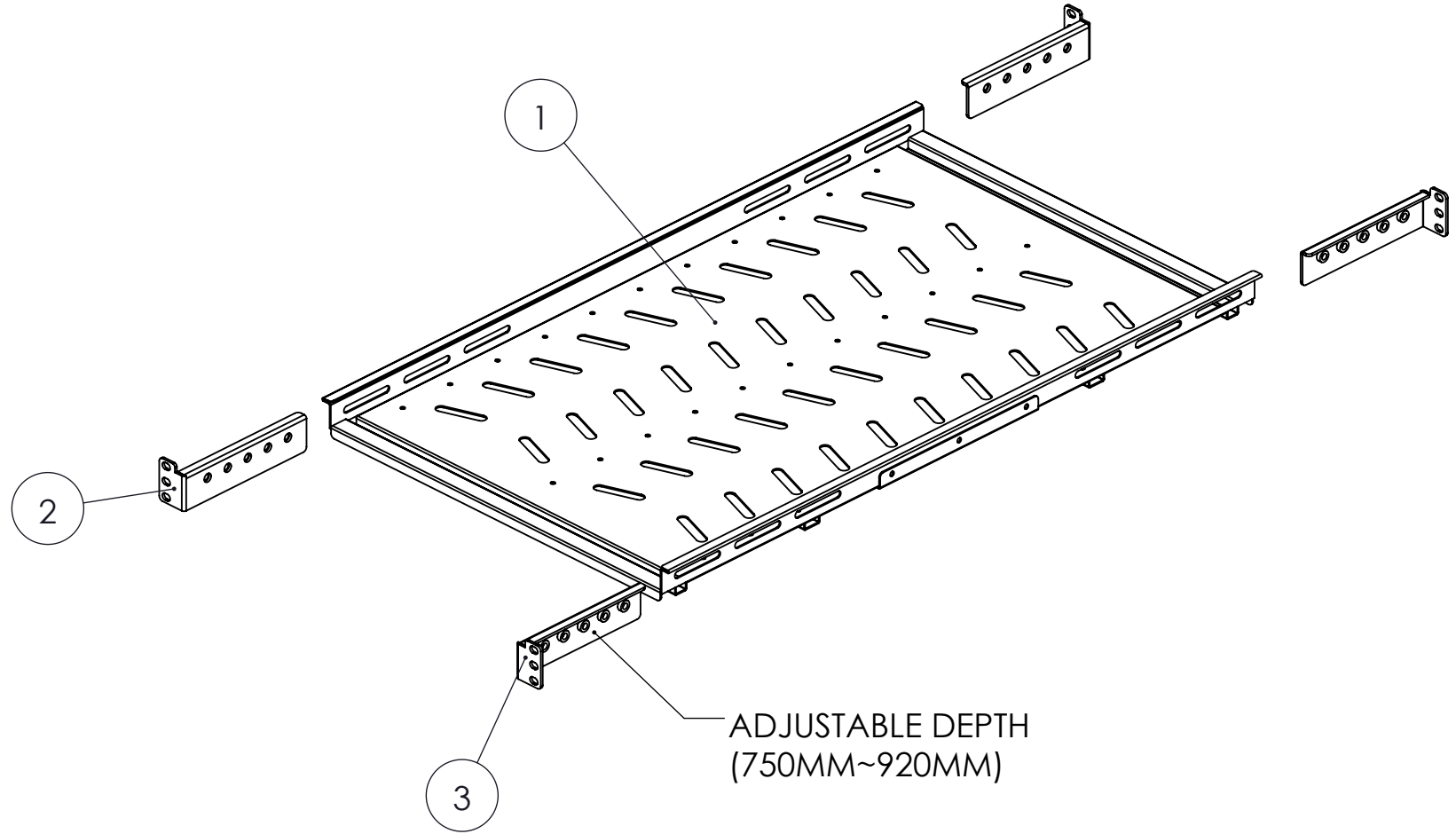
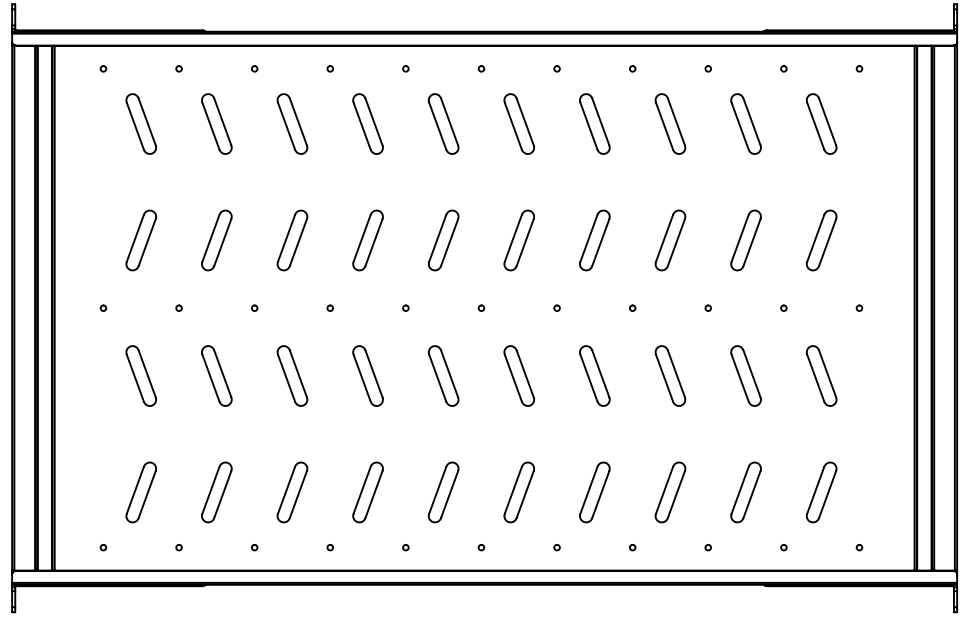

ADJUSTABLE DEPTH  
(750MM~920MM)

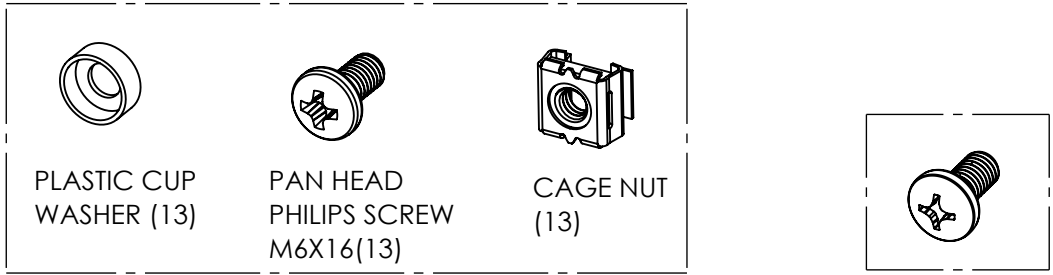

4

5

ITEM	LEVEL	PN	DES.	QTY.
1	1	1M2-W004	MAIN SHELF	1
/	1	OK0-W002	ACCESSORY BAG	1
2	2	1M2-W002	HANGING LEFT EAR	2
3	2	1M2-W003	HANGING RIGHT EAR	2
4	2	2F1-W102	CAGE NUT KITS	1
5	2	2F1-P0616-B	PAN HAED PHILIPS SCREW, M6X16, BLACK ZINC	16

**PROPRIETARY AND CONFIDENTIAL**  
THIS DRAWING AND ITS SPECIFICATIONS ARE THE PROPERTY OF INOVA AND SHALL NOT BE COPIED, REPRODUCED, OR USED IN WHOLE OR IN PART, AS THE BASIS FOR THE MANUFACTURE OR SALE OF ITEMS WITHOUT THE WRITTEN PERMISSION FROM INOVA. THIS DRAWING IS BASED UPON THE LATEST AVAILABLE INFORMATION AND IS SUBJECT TO CHANGE WITHOUT NOTICE.

UNLESS OTHERWISE SPECIFIED  
 X = ± 1  
 X.X = ± 0.5  
 X.XX = ± 0.30  
 X.XXX = ± 0.130  
 ANGULAR  
 X = 1°  
 .X = 0.5°  
 .XX = 0.25°  
 UNITS: mm [in]



DESCRIPTION:  
RACK ACCESSORY, FIX SHELF, 1U,  
19" WIDTH, 29.5" DEPTH, 200LBS  
LOADING, BLACK  
 MATERIAL: SPCC FINISH: RAL 9005 TEXTURE  
 DEBURR AND BREAK SHARP EDGES/CONTOURS AT 0.2mm MAX CLASS: N/A

DRAWING NO: <b>INV08-FSH750</b>		REV NO: <b>A</b>
NAME: AMY ZHU DATE: 2023/12/1		SIZE: B
APP. BY: SAM DING DATE: 2023/12/1		COMMENTS:
SCALE: 1:6	WEIGHT:	SHEET: 1 OF 2

8 7 6 5 4 3 2 1

NOTES:

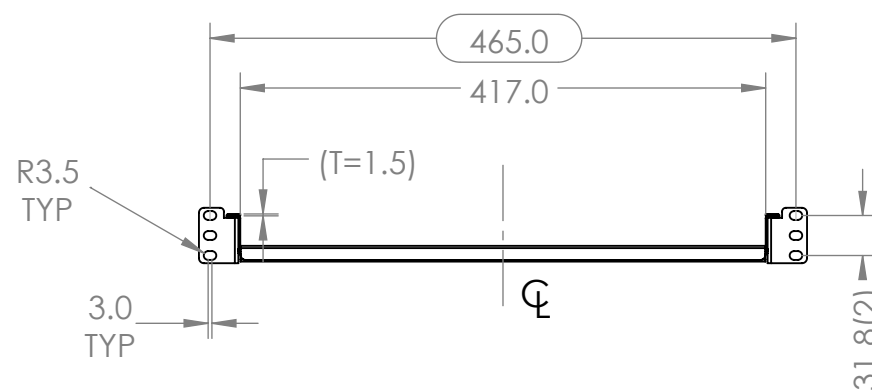
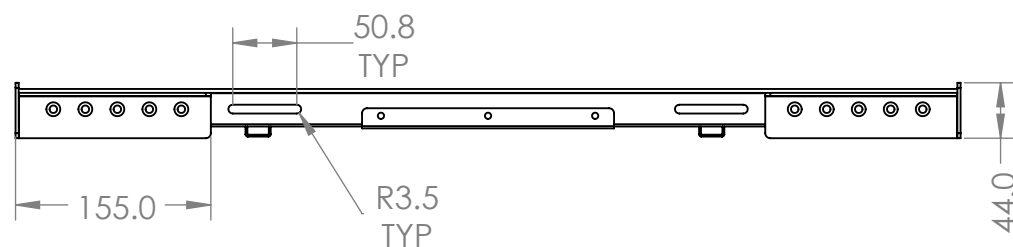
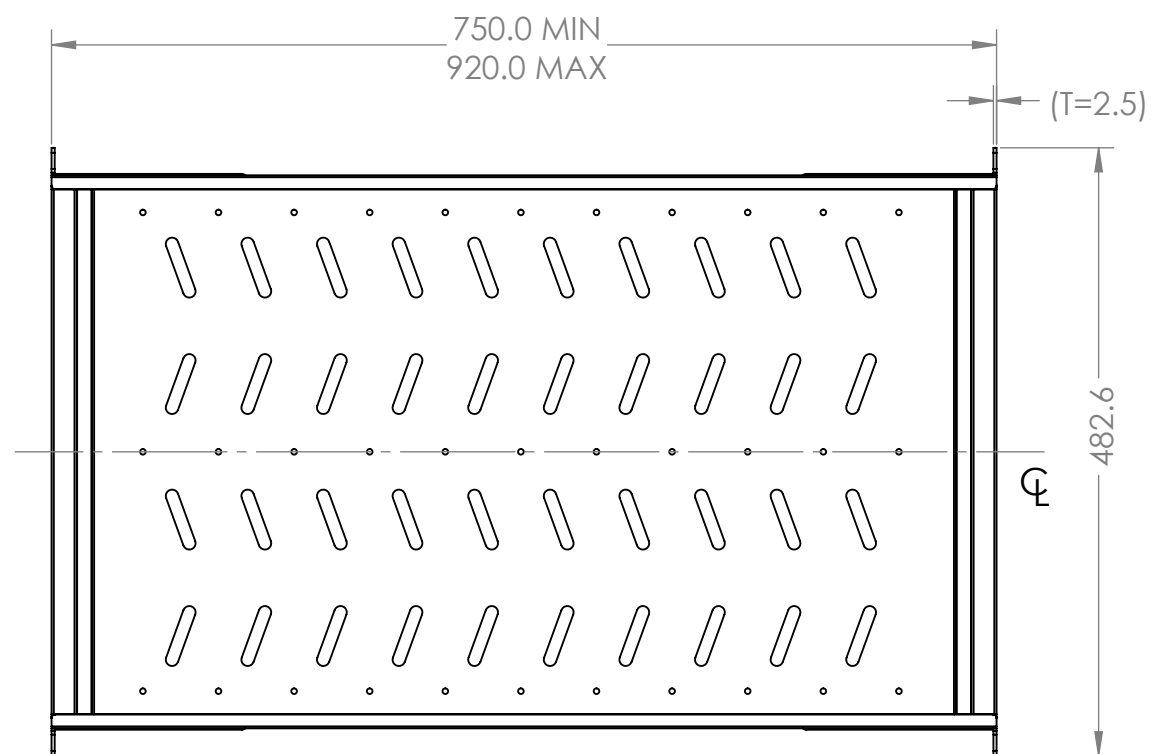

**PROPRIETARY AND CONFIDENTIAL**

THIS DRAWING AND ITS SPECIFICATIONS ARE THE PROPERTY OF INOVA AND SHALL NOT BE COPIED, REPRODUCED, OR USED IN WHOLE OR IN PART, AS THE BASIS FOR THE MANUFACTURE OR SALE OF ITEMS WITHOUT THE WRITTEN PERMISSION FROM INOVA. THIS DRAWING IS BASED UPON THE LATEST AVAILABLE INFORMATION AND IS SUBJECT TO CHANGE WITHOUT NOTICE.

UNLESS OTHERWISE SPECIFIED

X = ± 1  
 X.X = ± 0.5  
 X.XX = ± 0.30  
 X.XXX = ± 0.130  
 ANGULAR  
 X = 1°  
 .X = 0.5°  
 .XX = 0.25°



INTERPRET TO ASME Y14.100

DESCRIPTION:  
 RACK ACCESSORY, FIX SHELF, 1U,  
 19" WIDTH, 29.5" DEPTH, 200LBS  
 LOADING, BLACK

MATERIAL:

SPCC

FINISH:

RAL 9005 TEXTURE

DEBURR AND BREAK SHARP  
 EDGES/CONTOURS AT 0.2mm MAX

CLASS: N/A

DRAWING NO:

INV08-FSH750

REV NO:

A  
 B

NAME		DATE		COMMENTS:
DRAWN BY	AMY ZHU	2023/12/1		
APP. BY	SAM DING	2023/12/1		
SCALE:	1:10	WEIGHT:		SHEET: 2 OF 2