

NOTES:

REVISIONS			
REV.	DESCRIPTION	DATE	APPROVED

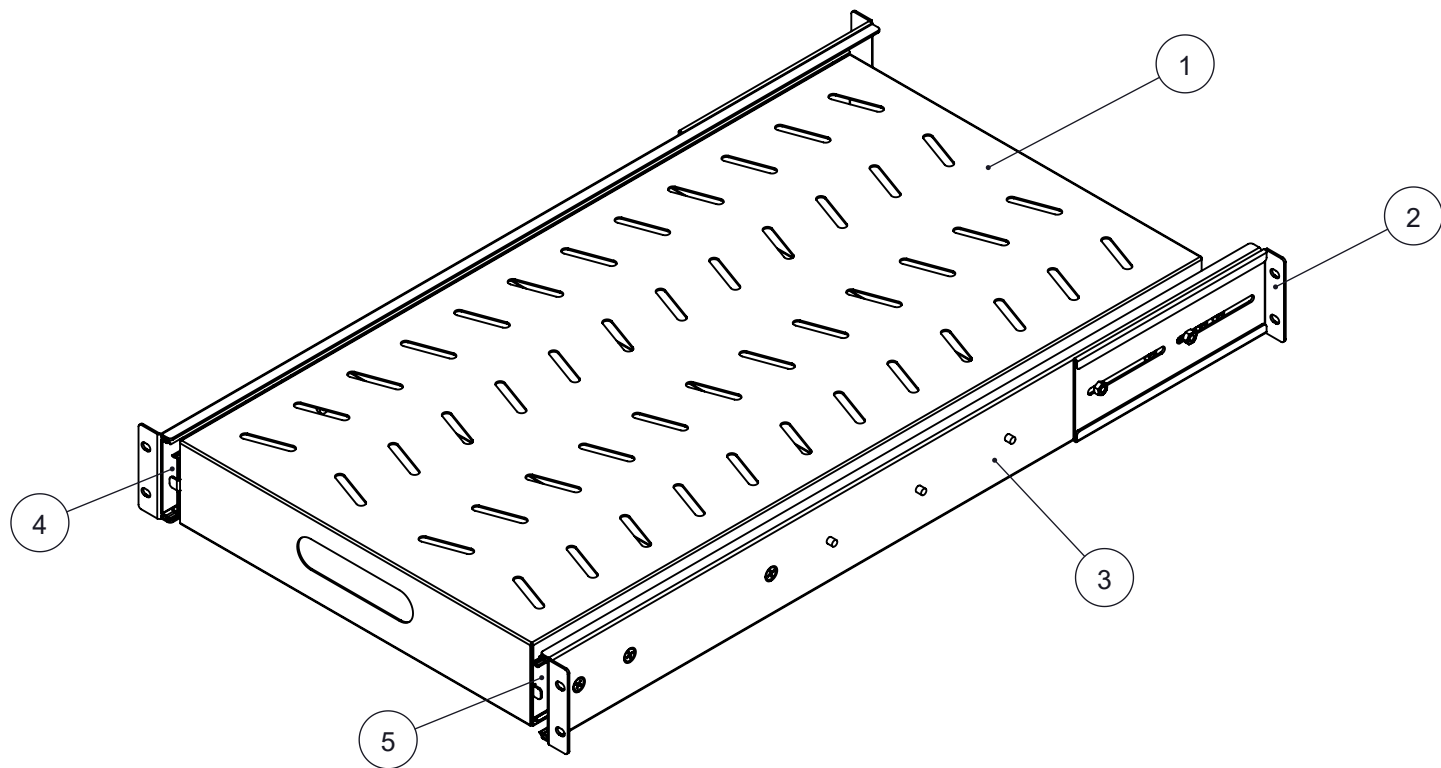
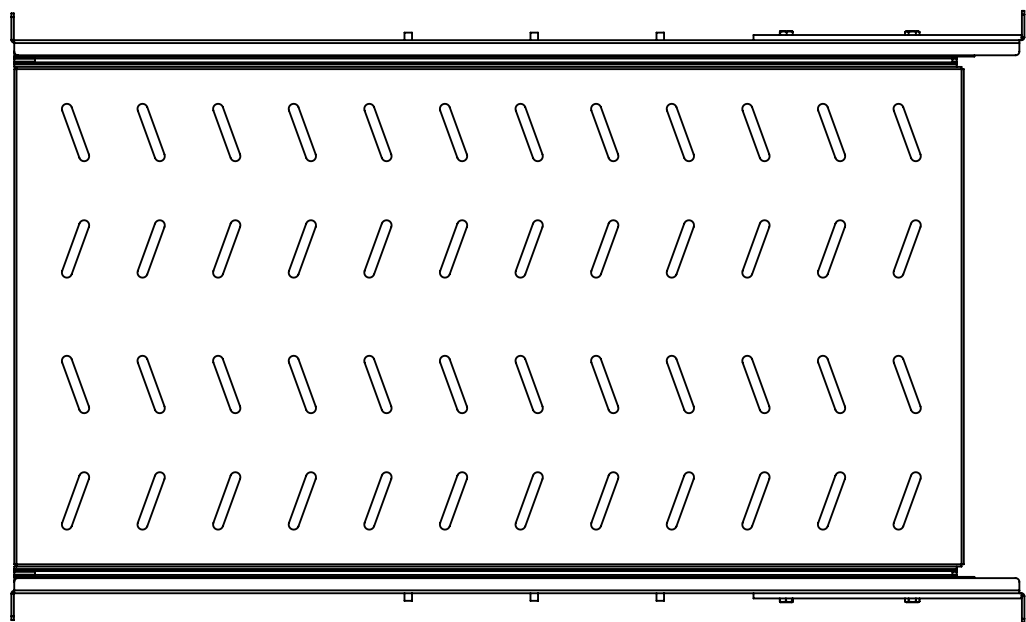

ITEM	PN	DES	QTY
1	1M2-Y010	SHELF BODY ASM, CRS+BLACK POWDER COATING, T=1.5MM	1
2	1M2-Y008	BEAM EAR, CRS+BLACK POWDER COATING, T=2MM	2
3	1M2-Y007	BEAM, CRS+BLACK POWDER COATING, T=2MM	2
4	1M9-Y001	GUIDE OUTER RAIL(SET)	1
5	1M9-Y001-inner	GUIDE INNER RAIL(SET)	1
6	ACCESSORY BAG	CAGE NUT KITS	1

PROPRIETARY AND CONFIDENTIAL
 THIS DRAWING AND ITS SPECIFICATIONS ARE THE PROPERTY OF INOVA AND SHALL NOT BE COPIED, REPRODUCED, OR USED IN WHOLE OR IN PART, AS THE BASIS FOR THE MANUFACTURE OR SALE OF ITEMS WITHOUT THE WRITTEN PERMISSION FROM INOVA. THIS DRAWING IS BASED UPON THE LATEST AVAILABLE INFORMATION AND IS SUBJECT TO CHANGE WITHOUT NOTICE.

UNLESS OTHERWISE SPECIFIED
 X = ± 1
 X.X = ± 0.5
 X.XX = ± 0.30
 X.XXX = ± 0.130
 ANGULAR
 X = 1°
 .X = 0.5°
 .XX = 0.25°
 UNITS: mm [in]



DESCRIPTION:
 CABINET ACCESSORY, SLIDING SHELF, HEAVY DUTY, 2U, 19" WITH, 19"~31.4" DEPTH, 400LBS, BLACK
 MATERIAL: SPCC
 FINISH: RAL9005 TEXTURE
 DEBURR AND BREAK SHARP EDGES/CONTOURS AT 0.2mm MAX
 CLASS: N/A

DRAWING NO: INV08-SSH750
 REV NO: A
 SIZE: B
 COMMENTS:
 DRAWN BY: AMY ZHU 2023/12/04
 APP. BY: SAM DING 2023/12/04
 SCALE: 1:6
 WEIGHT:
 SHEET: 1 OF 2

E
D
C
B
A

8 7 6 5 4 3 2 1

8 7 6 5 4 3 2 1

NOTES:

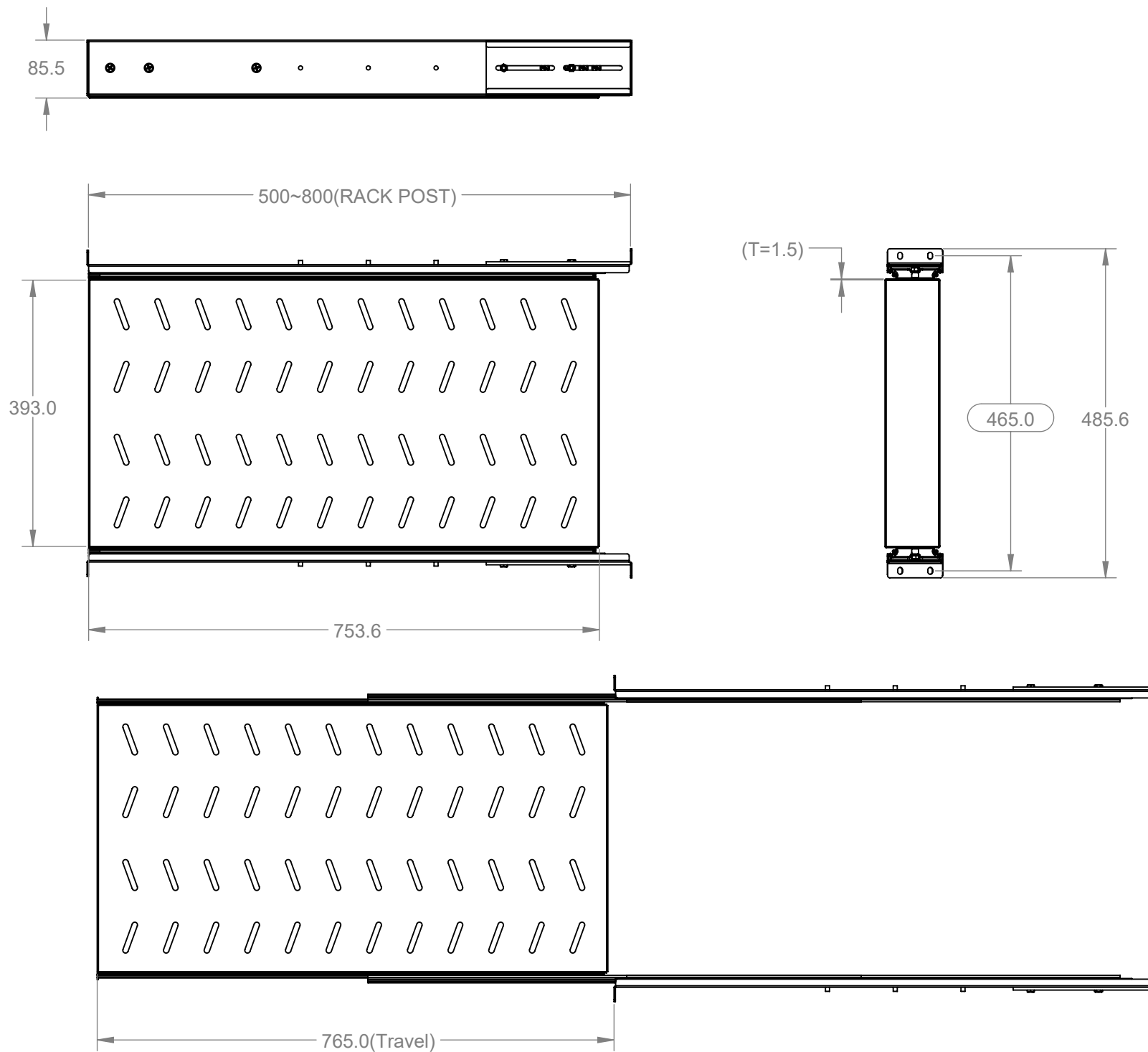

<p>PROPRIETARY AND CONFIDENTIAL</p> <p>THIS DRAWING AND ITS SPECIFICATIONS ARE THE PROPERTY OF INOVA AND SHALL NOT BE COPIED, REPRODUCED, OR USED IN WHOLE OR IN PART, AS THE BASIS FOR THE MANUFACTURE OR SALE OF ITEMS WITHOUT THE WRITTEN PERMISSION FROM INOVA. THIS DRAWING IS BASED UPON THE LATEST AVAILABLE INFORMATION AND IS SUBJECT TO CHANGE WITHOUT NOTICE.</p>	<p>UNLESS OTHERWISE SPECIFIED</p> <p>X = ± 1 X.X = ± 0.5 X.XX = ± 0.30 X.XXX = ± 0.130</p> <p>ANGULAR X = 1° .X = 0.5° .XX = 0.25°</p>		<p>INTERPRET TO ASME Y14.100</p>	<p>DESCRIPTION: CABINET ACCESSORY, SLIDING SHELF, HEAVY DUTY, 2U, 19" WITH, 19"~31.4" DEPTH, 400LBS, BLACK</p>		<p>DRAWING NO: INV08-SSH750</p>		<p>REV NO: A</p>
	<p>MATERIAL: SPCC</p>			<p>FINISH: RAL9005 TEXTURE</p>		<p>CLASS: N/A</p>		<p>SIZE: B</p>
	<p>DEBURR AND BREAK SHARP EDGES/CONTOURS AT 0.2mm MAX</p>			<p>SCALE: 1:8</p>		<p>WEIGHT:</p>		<p>COMMENTS:</p>
	<p>UNITS: mm [in]</p>			<p>SCALE: 1:8</p>		<p>WEIGHT:</p>		<p>SHEET: 2 OF 2</p>
		<p>DRAWN BY: AMY ZHU</p>		<p>DATE: 2023/12/04</p>		<p>APP. BY: SAM DING</p>		<p>DATE: 2023/12/04</p>