

NOTES:

REVISIONS			
REV.	DESCRIPTION	DATE	APPROVED
A	FULL RELEASED	2023/12/1	CT

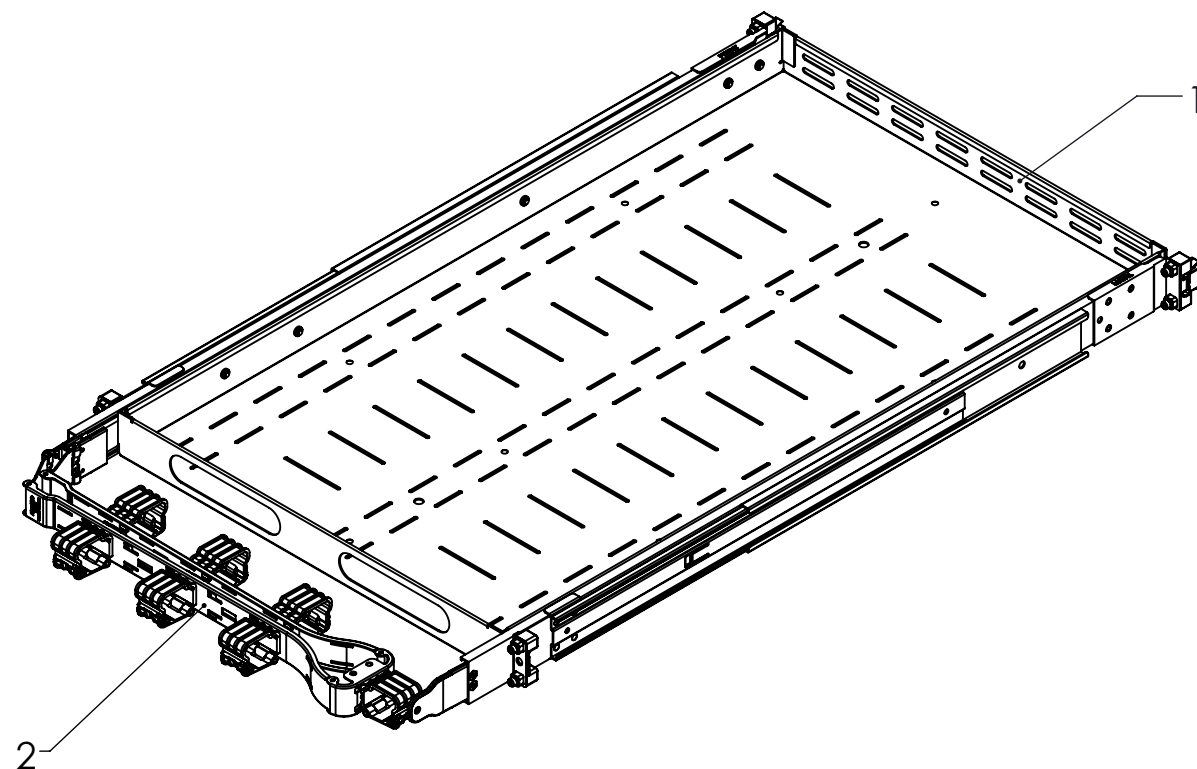
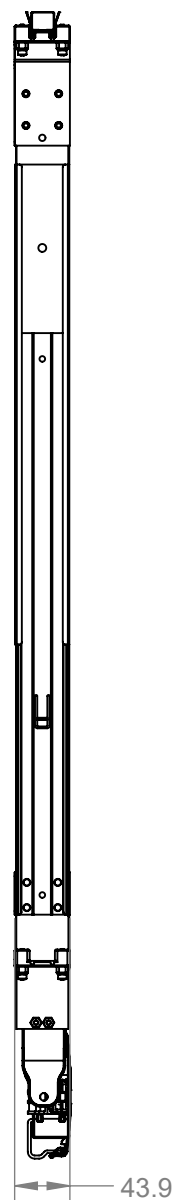
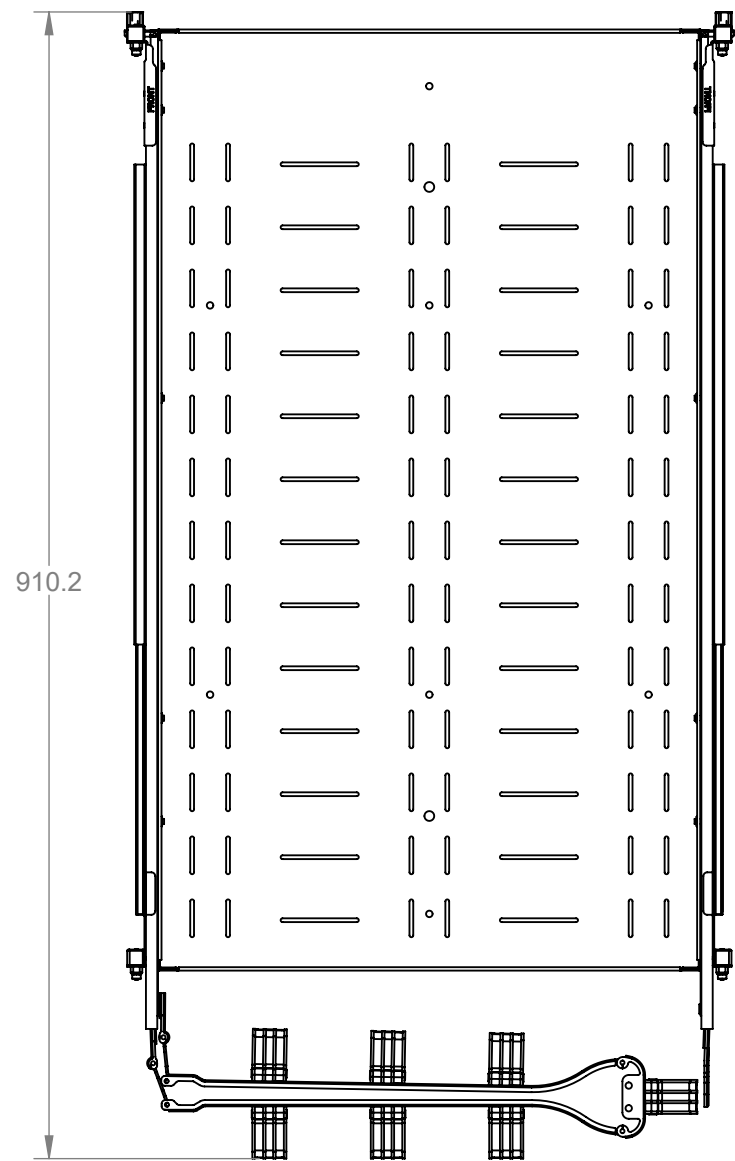

ITEM	PN	DES.	QTY.
1	INV08-SSK001	CABINET ACCESSORY, SLIDING SHELF, 1U, 19" WIDTH, 29.5" DEPTH, 90LBS LOADING, BLACK	1
2	2AA7-362FAZ0S3	CABLE MANAGER ARM	1

**PROPRIETARY AND CONFIDENTIAL**  
 THIS DRAWING AND ITS SPECIFICATIONS ARE THE PROPERTY OF INOVA AND SHALL NOT BE COPIED, REPRODUCED, OR USED IN WHOLE OR IN PART, AS THE BASIS FOR THE MANUFACTURE OR SALE OF ITEMS WITHOUT THE WRITTEN PERMISSION FROM INOVA. THIS DRAWING IS BASED UPON THE LATEST AVAILABLE INFORMATION AND IS SUBJECT TO CHANGE WITHOUT NOTICE.

UNLESS OTHERWISE SPECIFIED  
 X = ± 1  
 X.X = ± 0.5  
 X.XX = ± 0.30  
 X.XXX = ± 0.130  
 ANGULAR  
 X = 1°  
 .X = 0.5°  
 .XX = 0.25°  
 UNITS: mm [in]



DESCRIPTION:  
 CABINET ACCESSORY, SLIDING SHELF, 1U, 19" WIDTH, 29.5" DEPTH, 90LBS LOADING, WITH CABLE MANAGEMENT ARM, BLACK  
 MATERIAL: N/A  
 FINISH: RAL 9005 TEXTURE  
 DEBURR AND BREAK SHARP EDGES/CONTOURS AT 0.2mm MAX  
 CLASS: N/A

DRAWING NO:		REV NO:	
INV08-SSK1CM		A	
NAME		DATE	
DRAWN BY: AMY ZHU		2023/12/1	
APP. BY: SAM DING		2023/12/1	
SCALE: 1:6	WEIGHT:	SHEET: 1 OF 1	

Grid labels: 8, 7, 6, 5, 4, 3, 2, 1 (top and bottom); E, D, C, B, A (left and right)